

ALCATEL

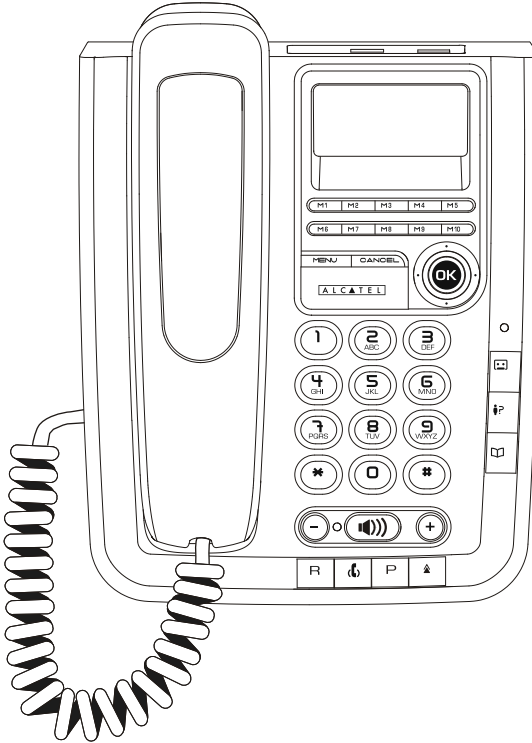

**TEMPORIS™ 500**  
**User Guide**

# CONTENTS

<b>1. DESCRIPTION OF THE TEMPORIS 500</b>	<b>PAGE 3</b>
1.1 Display .....	4
1.2 Equipment supplied .....	5
1.3 Characteristics .....	5
<b>2. INSTALLING YOUR TEMPORIS 500</b>	<b>PAGE 6</b>
2.1 Connecting the handset .....	6
2.2 Connecting the base .....	7
2.3 Wall mounting .....	7
2.4 Inserting or replacing the batteries .....	8
2.5 Declaration of conformity .....	8
<b>3. GENERAL USE</b>	<b>PAGE 9</b>
3.1 Message waiting / Ringing indicator light .....	9
3.2 Call in progress light .....	9
3.3 Pre-dialing / on-hook dialing .....	9
3.4 Dialing using a memory .....	10
3.5 Receiving a call .....	11
3.6 Using hands-free mode .....	11
3.7 Adjusting the handset volume .....	11
3.8 Using the mute function .....	11
3.9 Putting a call on hold / transferring a call .....	12
3.10 Redialing the last numbers called .....	12
<b>4. PROGRAMMING YOUR TEMPORIS 500</b>	<b>PAGE 14</b>
4.1 Contrast .....	15
4.2 Language .....	15
4.3 Selecting and adjusting the melody & the volume .....	16
4.4 Setting date and time .....	17
4.5 Call setting .....	18
4.5.1 Area code .....	18
4.5.2 Prefix number .....	19
4.5.3 Voice mail setting .....	20
4.5.4 Dial mode setting .....	21
4.5.5 Flash time setting .....	22
4.5.6 Pause time setting .....	23

4.6	Lock / Unlock .....	24
4.7	Creating / Modifying or deleting a directory record / direct access memories .....	25
4.8	Changing the PIN .....	28
4.9	Programming the mailbox number .....	29

**5. USING THE "CALLER IDENTIFICATION" SERVICES PAGE 30**

5.1	List of Calls .....	30
5.2	To consult the call log .....	31
5.3	Saving a record from the list of calls .....	32
5.4	Deleting a record from the list of calls .....	32
5.5	Calling a correspondent from the list of calls .....	32

**6. CONNECTING AND USING A HEADSET PAGE 33**

6.1	Connecting a headset .....	33
6.2	Using a headset .....	33

**7. ADDITIONAL INFORMATION PAGE 34**

7.1	Troubleshooting .....	34
7.2	Defaults settings .....	35
7.3	Guarantee .....	36
7.4	Environment .....	37
7.5	Safety .....	37
7.6	Precautions .....	38

# 1. DESCRIPTION OF THE TEMPORIS 500

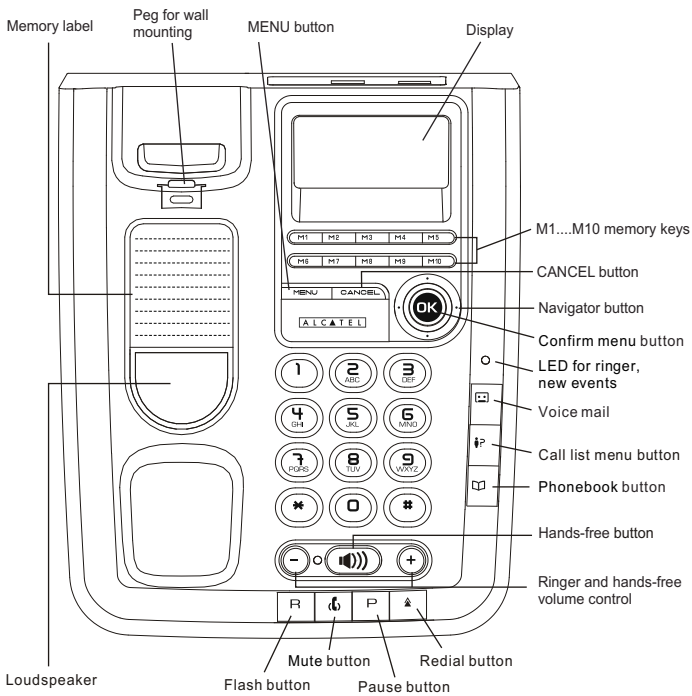

## 1.1 DISPLAY

The TEMPORIS 500 has a three-line display:

- 1 line of icons and information about the functions
- 1 line 16 digits.
- 1 line of 16 alphanumerical characters.

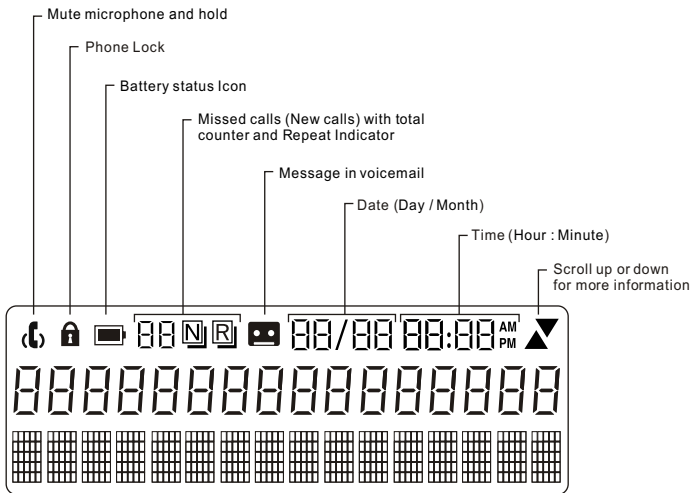



## 1.2 EQUIPMENT SUPPLIED

- 1 **TEMPORIS 500** telephone set
- 1 coiled cable
- 1 RJ11/RJ11 telephone cable (depends on countries)
- 1 memory label
- 7 user guides (English, French, Spanish, German, Dutch, Portuguese and Italian)
- 1 plug adapter (depends on countries)

## 1.3 CHARACTERISTICS

- 50 names and numbers phonebook directory
- RJ9 headset connection
- Calls can be made by selecting the name from the directory
- 10 direct access memories
- Access to Caller Name and/or Calling Line Identification services\*
- Caller's name and number displayed\*
- Lists the last 30 calls received\*
- Voice mail access\*
- Duration of call displayed
- 5 extended last number redial function
- 4 ringtones selection
- Adjustable ringer volume with silent option
- Mixed dialing: tone or pulse (33/66) or pulse (40/60)
- Pre-dialing / on-hook dialing
- Adjustable handset volume
- Hands-free mode with adjustable loudspeaker volume
- Mute key to disable the microphone or put the caller on hold
- Date and time settings
- Call barring



\* If the service is available and a subscription has been taken out (on public service telephone line only).



## 2. INSTALLING YOUR TEMPORIS 500

### 2.1 CONNECTING THE HANDSET

Connect one end of the coiled cable (**A**) to the handset and the other end (**B**) to the plug on the left-hand side of the base.

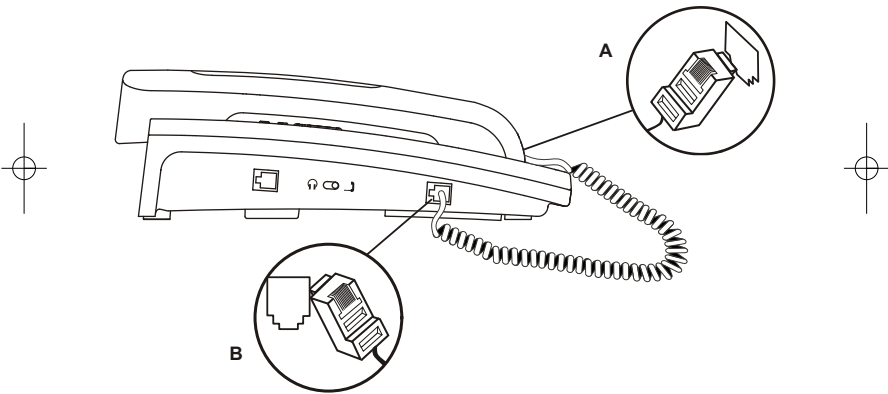



## 2.2 CONNECTING THE BASE

- Connect one end of the telephone cable to the socket on the back left-hand side of the base (**C**)

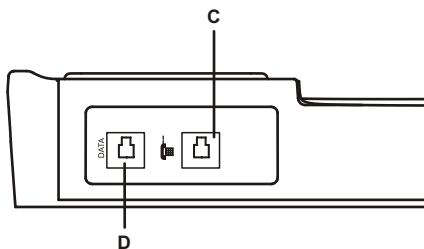

NOTE: The other socket (**D**) is for connecting a modem.

## 2.3 WALL MOUNTING

To wall mount the telephone set, remove, reverse and reinsert the mounting peg as shown in the figure below.

Drill two horizontal holes of 6mm diameter with 86mm apart. Insert two wall plugs and screws (3.5mm diameter and 25mm long) leaving the screw head protruded. Place the cord in the slot under the base and hang the telephone onto the screws.

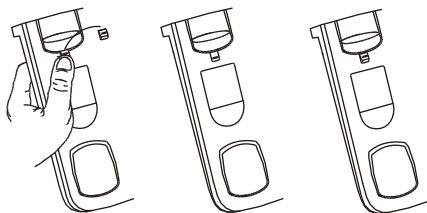

Wall mounted position

Horizontal position





## 2.4 INSERTING OR REPLACING THE BATTERIES

Your phone uses 4 LRO3-AAA 1.5V alkaline batteries (not included).

Insert or replace the batteries as described below:

- For safety reasons, always unplug the telephone line first.
- Open the battery compartment on the bottom of the base. Push down hard on the door while sliding it back.
- Remove the used batteries and insert the new ones. Pay attention to the '+' and '-' polarity indicated in the battery compartment.
- Close the battery compartment and re-connect the telephone set.
- Batteries will last for approximately 6 months under normal conditions of use.
- When the batteries are drained, the battery icon  will start flashing. You must then replace them with a fresh batteries as soon as possible.

**NOTE:** Your **TEMPORIS 500** still work properly without batteries or with empty batteries. However if you disconnect it from the telephone line, it will lose information like the date and time and directory records except the content of the one-touch memories.



## 2.5 DECLARATION OF CONFORMITY



- The **TEMPORIS 500** is certified in accordance with European regulations, as indicated by the **CE** marking.
- The **TEMPORIS 500** is intended to transmit and receive telephone calls and for connection behind a private branch exchange (**PBX**) or a public network of the European community.
- It is designed for connection to a TRT3 class (telecommunications network voltage) analogue telephone line, as defined in the EN60950-1 standard.
- Thomson Telecom hereby declares that the **TEMPORIS 500** conforms to the essential requirements and other relevant provisions of directive 1999/5/CE.



## 3. GENERAL USE

### 3.1 MESSAGE WAITING / RINGING INDICATOR LIGHT

When you receive a call, the light flashes with the same rhythm as the ringtone. If you have subscribed to the "Caller Identification" service, the light also indicates that there are new calls or messages in the list of calls. If you are connected to a private ALCATEL telephone system with a messaging service, this light indicates that there is a message in your voice mailbox.

### 3.2 CALL IN PROGRESS LIGHT

When you pick up your handset or seize the line in hands-free mode, the light associated with the  button will come on and stay on as long as the line is busy.

### 3.3 PRE-DIALING / ON-HOOK DIALING

Insert or replace the batteries as described below:



#### • MAKING A CALL

- 1 Dial your correspondent's number.



Press the  button to delete any incorrect numbers.



- 2 Press the  or  button.

The loudspeaker light lite on.



- 3 Adjust the volume using the  and  button.



- 4 Press the  button to end the call.

or

- 4 Lift the handset to continue with the conversation in private.

NOTE: The call duration counter starts about 16 seconds after the last digit has been dialled.

### • OTHER WAYS OF MAKING A CALL

You can also make a call in other ways:

- Dialing the number and then lift up the handset.
- Press the  button and then dial the number.
- Lift up the handset and then dial the number.

## 3.4 DIALLING USING A MEMORY



Each memory can hold 20 digits and 16 characters.





### • CALLING FROM THE DIRECTORY

- 1** Press the  button.



- 2** There are two ways of searching for a number:
  - Use the  and  buttons to scroll through the names in the directory until the one you want is displayed.

- 3** Use the  and  buttons to shift the phone number if more than 16 digits.



- 4** Press the  button to make the call.

or



- 4** Use the  to enter your correspondent's number.

or

- 4** lift the handset to make the call.

NOTE: The call duration counter starts 16 seconds after the last digit has been dialled.

### • CALLING FROM A DIRECT MEMORY



- 1** Just press the selected direct access memory button.  
The loudspeaker light lite on.

- 2** Pick up the handset when your correspondent answers.

or

- 2** Start the conversation in hands-free mode.

NOTE: The call duration counter starts 16 seconds after the last digit has been dialled.

### 3.5 RECEIVING A CALL

There are two ways to answer the call:

- Lift the handset.
- Press the  button, then start the conversation in hands-free mode.

NOTE: -If the ringer is disabled, the incoming call will signal on both the display and LED (flashing). Answer the call as described above.

- The call duration counter starts as soon as you answer the call.

### 3.6 USING HANDS-FREE MODE

If you are in conversation using the handset and wish to change to the loudspeaker instead:



- 1 Press the  button and replace the handset.
  - ▶ The others around you can participate in the conversation.



- 2 Adjust the volume using the  and  buttons.

- 3 Lift the handset to return to a private conversation.

### 3.7 ADJUSTING THE HANDSET VOLUME

When the loudspeaker is disabled, you can increase the handset volume.



- 1 Press the  button in order to increase the volume.





- 2 Press the  button in order to decrease the volume.

### 3.8 USING THE MUTE FUNCTION

This feature allows you disable your conversation from being heard by your correspondent during a conversation.



- 1 Press the  button.
  - ▶ Your correspondent can no longer hear you. The mute icon will be displayed.
- 2 Press the  button again to resume the conversation.

### 3.9 PUTTING A CALL ON HOLD / TRANSFERRING A CALL

You can put your correspondent on hold whilst you transfer your call to another parallel telephone in another room.



- 1 Press the  button.
  - ▶ Your correspondent can no longer hear you. The mute icon will be displayed.
- 2 Replace the handset.
  - ▶ Both you and your correspondent hear a beep in approximately 10 seconds interval. Mute icon will start flashing.
- 3 Pick up the handset to resume the conversation.

or

Pick up the handset of the second telephone set to resume the conversation on that phone.

The **TEMPORIS 500** releases the line.

### 3.10 REDIALING THE LAST NUMBERS CALLED

The redial memory's capacity is 32 digits.  
There are two ways to redial the last number called:

- IN OFF-HOOK MODE



- 1 Press the  button.

▶ 

05
01 23 4567 89

The telephone automatically dial the last number called.



• IN ON-HOOK MODE - EXTENDED REDIALING OF LAST NUMBER



The **TEMPORIS 500** records the last 5 numbers called.





**1** Press the  button.

▶ The last number called is displayed.



**2** Use the  or  buttons to display the last 5 numbers called.



**3** Press the  button or lift the handset or press the hands-free key .

The telephone will dial the number automatically.

• DELETING A NUMBER



If you do not want the last numbers you called to be reviewed, you can delete them individually.



**1** Press the  button.

▶ The last number called is displayed.





**2** Use the  or  buttons to select the number to delete .



**3** Press the  button.



**4** Use  or  buttons to select "ERASE?" (to delete the selected number)

or

"ERASE ALL?" (to delete all the number)















**5** Press the  button confirm erase.



## 4. PROGRAMMING YOUR TEMPORIS 500













Your **TEMPORIS 500** has a configuration menu. To access the different sub-menus, when the telephone is in stand-by mode, follow the instructions given below. You can return to stand-by mode from any point in the menu or sub-menu by pressing the **[MENU]** button again. Any procedure that has been started but not terminated will be aborted.

If you make an error, e.g. entered wrong data, you will be prompted with 3 beeps tone.

- |   |          |   |                    |
|---|----------|---|--------------------|
|   | ▶        | <input type="text" value="12 NEW CALLS"/>   | Stand-by screen.   |
|    | <b>1</b> | Press the <b>[MENU]</b> button.   |                    |
|   | ▶        | <input type="text" value="CONTRAST"/>   |                    |
|   | <b>2</b> | Press the  button.   |                    |
|   | ▶        | <input type="text" value="LANGUAGE"/>   | Select language.   |
|    |          | Each new press on the  button gives access to the next sub-menu. |                    |
|    | ▶        | <input type="text" value="CONTRAST"/>   | Set contrast.      |
|    | ▶        | <input type="text" value="LANGUAGE"/>   | Set language.      |
|    | ▶        | <input type="text" value="RING TONE"/>  | Set ring tone.     |
|    | ▶        | <input type="text" value="DATE/TIME"/>  | Set date and time. |
|  | ▶        | <input type="text" value="CALL SETTING"/>   | Set call setting.  |
|  |          | Call barring menu.  | Or unlock?         |
|  | ▶        | <input type="text" value="LOCK?"/>  |                    |
|  | ▶        | <input type="text" value="CHANGE PIN CODE?"/>   | Change the PIN.    |

**NOTE:** When a function is validated the screen displays "SAVED" and the telephone returns to the previous state after 1.5 seconds.



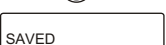







#### 4.1 CONTRAST

-  **1** Press the  button.
- ▶ 
-  **2** Press the  button.
- ▶ 
-  **3** Press the  and  button to adjust the contrast.
- ▶ 
-  **4** Press the  button to confirm.
- ▶ 

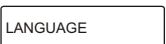
#### 4.2 LANGUAGE

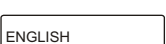
The **TEMPORIS 500** offer 7 languages display:

- English, French, Spanish, German, Dutch, Portuguese, Italian.



-  **1** Press the  button.
- ▶ 
-  **2** Press the  button.
- ▶ 
-  **3** Press the  button.
- ▶ 
-  **4** Press the  button, to confirm the language selection.
- ▶ 

NOTE: Repeat the same procedure for other languages.

### 4.3 SELECTING AND ADJUSTING THE MELODY & THE VOUME

There are two ways of selecting and adjusting the melody:

- You can change the melody while the telephone is ringing before answering the call.

 **1** Use the  and  buttons to adjust the volume.

 ▶

 **2** Use  to  buttons to select the melody.



 ▶

NOTE: When the changes are recorded, you can answer the call.

#### · PROGRAMMING

 **1** Press the  button.

 ▶

 **2** Press the  button until the screen displays "RING TONE".

 ▶

 **3** Press the  button.

 ▶

**4** Pick up the handset.

 ▶

The telephone starts ringing.

 **5** Use the  and  buttons to modify the melody (1 to 4) off.

 ▶

 **6** Use the  and  buttons to increase or decrease the volume.

 ▶

 **7** Press the  button.

 ▶

**8** Replace the handset.

#### 4.4 SETTING DATE AND TIME

The date and time icons flash until the date and the time are updated.



- 1** Press the button.

▶ CONTRAST



- 2** Press the button until the screen displays "DATE/TIME".

▶ DATE/TIME



- 3** Press the button.

▶ 18/04 10:20  
SET DATE



- 4** Use the keypad to change the date in DD/MM.

▶ 18/05 10:20  
SET DATE



- 5** Press the button.

▶ 18/05 10:20  
SET TIME



- 6** Press the button to save.

▶ 18/05 08:20  
SAVED

· HOUR FORMAT



- 7** Press the button.

▶ 24H  
HOUR FORMAT



- 8** Select 12H or 24H using or button.

▶ 24H  
HOUR FORMAT



- 9** Press the button to save.

▶ SAVED

Note: In certain countries, the date and time are update automatically if you subscribe to the CLI service.

## 4.5 CALL SETTING

### · 4.5.1 AREA CODE



When receive a CLI number that does not match with the area code, a prefix numbers should be added to the first number for redial.



- 1 Press the  button.



▶ CONTRAST



- 2 Select "CALL SETTING" using the  or  button.

▶ CALL SETTING



- 3 Press the  button to confirm, and select "AREA CODE" using the  and  button.

▶ AREA CODE



- 4 Press the  button to confirm.

▶ 302  
AREA CODE



- 5 If it is necessary to change the area code, enter the new code using the "0~9" numeral keys. The cursor will move to next digit automatically.

▶ 22  
AREA CODE

Note: Once a number key is pressed, the preset area code will be cleared.

Remark: Whenever "CANCEL" key has pressed, whole area code is deleted.



- 6 Press the  button to confirm the change.

▶ SAVED

Remark: Area code is not in use in European countries and should be left blank.

#### · 4.5.2 PREFIX NUMBER



- 1 Press the button.

▶ CONTRAST



- 2 Select "CALL SETTING" using the or button.

▶ CALL SETTING



- 3 Press the button to confirm, and select "PREFIX NUM" using the and button.

▶ PREFIX NUM



- 4 Press the button to confirm. The prefix number will be displayed and flashing.

▶ 020  
PREFIX NUM



- 5 If it is necessary to change the prefix number, enter the new number using "0~9" numeral keys. The cursor will move to next digit automatically.

▶ 35  
PREFIX NUM

Note: Once a number key is pressed, the preset prefix number will be cleared.

Remark: Whenever "CANCEL" key has pressed, whole prefix code is deleted.



- 6 Press the button to confirm the change.

▶ SAVED

After 2 second, it returns to standby mode.

Remark: Prefix code is not in use in European countries and should be left blank.

### · 4.5.3 VOICEMAIL SETTING

To verify or change voicemail number (16 digits):



- 1 Press the button.

▶ CONTRAST



- 2 Select "CALL SETTING" using the or button.

▶ CALL SETTING



- 3 Press the button to confirm, and select "VOICEMAIL" using the or button.

▶ VOICEMAIL



- 4 Press the button to confirm and the voicemail number will be displayed .

▶ 302  
VOICEMAIL



- 5 If it is necessary to change the voicemail number , enter the new number with "0~9" numeral keys. The cursor will move to the next digit automatically.

▶ 388556  
VOICEMAIL

Note: Once a number key is pressed, the last set voicemail number would be cleared.

Remark: When the entry is more than 16 digits, the unit will emit error beep tone.



- 6 Press the button to validate.

▶ SAVED

Note: Default setting: the voice mail number is empty.



#### · 4.5.4 DIAL MODE SETTING

To select dial mode (tone / pulse 40 / 60 / pulse 33 / 66):





1 Press the  button.



2 Select "CALL SETTING" using the  or  button.



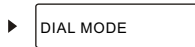

3 Press the  button to confirm, and select "DIAL MODE" using the  or  button.



4 Press the  button to confirm.



5 Select "DIALMODE" using the  or  button

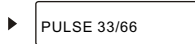

6 Press the  button to confirm.



#### · 4.5.5 FLASH TIME SETTING



- 1** Press the button.

▶ CONTRAST



- 2** Select "CALL SETTING" using the or button.

▶ CALL SETTING



- 3** Press the button to confirm, and select "FLASH TIME" using the or button.

▶ FLASH TIME



- 4** Press the button to confirm, and select "FLASH TIME INPUT" using the or button.

▶ 085  
FLASH TIME INPUT



- 5** If it is necessary to change the flash time, enter the new setting with the "0~9" numeral keys. The cursor will move to next digit automatically.

▶ 125  
FLASH TIME INPUT

Note: 1. Once a number key is pressed, the last set flash time will be cleared.  
2. The flash time setting range is between 70ms~650ms.  
3. If the entered value is not within this range, it will reset the last set value.



- 6** Press the button to confirm the edit.

▶ SAVED

Note: Default flash setting: 100ms



### · 4.5.6 PAUSE SETTING



1 Press the  button.



▶ CONTRAST



2 Select "CALL SETTING" using the  or  button.



▶ CALL SETTING



3 Press the  button to confirm, and select "PAUSETIME" using the  or  button.

▶ PAUSE TIME



4 Select input (Either 2 or 4 sec) using the  or  button

▶ PAUSE TIME INPUT  
2



5 Press the  button to confirm the edit.

▶ SAVED

Note: Default setting: the pausetime is 2 seconds.

## 4.6 LOCK / UNLOCK

When your telephone is locked:

- You can receive a call.
- You can dial up to 6 digits.

**The default PIN is 0000.**

### • LOCKING

**1** Press the **MENU** button, use  until you reach "LOCK?" menu.

▶ LOCK?



**2** Press the **OK** button.

▶ ENTER PIN CODE



**3** Enter your PIN.

▶ ENTER PIN CODE



**4** Press the **OK** button.

▶ PHONE LOCKED

If the PIN is incorrect, the display inform and ask you to try again.

### . UNLOCKING

**1** Press the **MENU** button.

▶ UNLOCK?



**2** Press the **OK** button.

▶ ENTER PIN CODE

**3** Enter your PIN.

▶ ENTER PIN CODE



**4** Press the **OK** button.

▶ PHONE UNLOCKED

If the PIN is incorrect, the display inform and ask you to try again.

**NOTE:** If you forget your PIN, consult the " TROUBLESHOOTING " chapter.

#### 4.7 CREATING / MODIFYING OR DELETING A DIRECTORY RECORD / DIRECT ACCESS MEMORIES



You can use this sub-menu to program both the directory and the direct access memories.

Your telephone has a directory with 50 entries. Each record is made up of a name and a number.



- 1** Press the  button or access keys (from M1 to M10).



- 2** Press the  button, then press the  button until the screen displays the right sub-menu.

▶ NEW?



- 3** Press the  button.

▶ \_

- 4** Use the keypad to enter your correspondent's name. Wait for the cursor to moved before entering the next letter.

To display M press the  button once.

To display A press the  button once

To display R press the  button 3 times.

To display Y press the  button 3 times.

To insert a space, press  .

▶ MARY



- 5** Press the  button.

▶ MARY



- 6** Use the keypad to enter your correspondent's number.

▶ 123456789  
MARY



- 7** Press the  button to save the data in the directory.

▶ SAVED

NOTE: - Use the  button to change a wrong entered character or number before saving.

• MODIFYING A DIRECTORY RECORD



1 Press the button then use to buttons to select the record.



2 Press the button.

▶ EDIT?



3 Press the button to confirm the selection.

4 Modify the name, press to modify the number and then press .

▶  or



5 Use the button to delete any characters. Use the keypad to modify name or number.

▶  or



6 Press the button to save the data in the directory.

▶



• ERASING A DIRECTORY RECORD

Repeat step **1** and **2**.



**3** Select "ERASE?" using the or buttons.

▶ ERASE?



**4** Press the button to confirm.

▶ ERASED

• ERASING ALL DIRECTORY RECORD

Repeat step **1** and **2**.



**3** Select "ERASE ALL?" using the or buttons.

▶ ERASE ALL?





**4** Press the button to confirm.



▶ ALL ERASED

## 4.8 CHANGING THE PIN



To access some features of the **TEMPORIS 500** you need to use a PIN.  
**The default PIN is 0000.** You can change it to your own code.

- 



**1** Press the  button.

▶ 
- 



**2** Press the  button until the screen displays "CHANGE PIN CODE?".

▶ 
- 



**3** Press the  button.

▶ 
- 



**4** Enter the old PIN.

▶ 
- 



**5** Press the  button.

▶ 
- 



**6** Enter the new PIN.

▶ 
- 

**7** Press the  button.

▶ 
- 

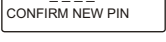
**8** Confirming the new pin by entering it again.



▶ 
- 



**9** Press the  button to save.



▶ 



#### 4.9 PROGRAMMING THE MAILBOX NUMBER



If you have programmed a mailbox number, it will dial automatically when you press the mailbox key.

- 
**1** Press the  button.
 



▶ CONTRAST
  
- 
**2** Press the  button until the screen displays "CALL SETTING".
 

▶ CALL SETTING
  
- 
**3** Press the  button.
 

▶ AREA CODE
  
- 
**4** Press the  button to select voice mail.
 

▶ VOICEMAIL
  
- 
**5** Press the  button.
 

▶ VOICEMAIL
  
- 
**6** Enter the phone number.
 

▶ 345678  
VOICEMAIL
  
- 
**7** Press the  button to save.
 

▶ SAVED

## 5. USING THE "CALLER IDENTIFICATION" SERVICES\*

Your operator offers some services that are only available if you subscribe to them. The **TEMPORIS 500** can work with the Caller Identification (CLI) service in on-hook mode or in conversation mode with a call waiting. The CLI service informs you of the calling party's number or name before you answer the call.

**This service is only available by subscription on public service telephone lines and on some PBXs. To subscribe: please contact your operator.**

### 5.1 LIST OF CALLS\*

The list of calls is linked to the CLI service offered by your operator.

It can record 30 different numbers of people whom have contacted you. When there is insufficient memory space, the oldest record will be replaced by the latest one.

The display gives you the following information about the CLI service:

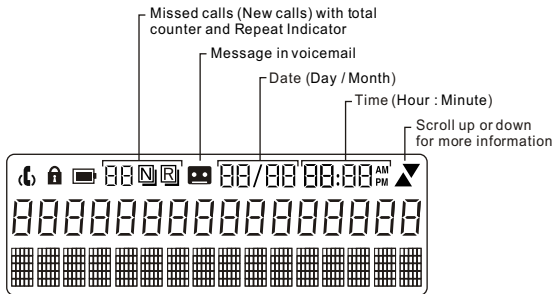

When a new calling line identity is received, the related information is recorded in the list of calls and the indicator light starts flashing.

\* On subscription from your network operator, subject to availability.

## 5.2 TO CONSULT THE CALL LOG



The message light flashes.



New calls in the list of calls.



New message your mailbox.



1 Press the  button.

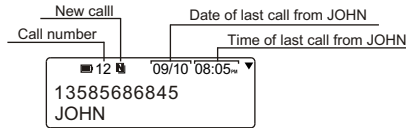

You have been called by:

- JOHN
- From line 13585686845
- Last call was on October 9th at 8.05 PM.



2 Press the  button.

You see the second new call.

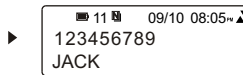

### 5.3 SAVING A RECORD FROM THE LIST OF CALLS

When a call record is displayed:



- 1 Press the button.

▶ STORE?



- 2 Press the button.

▶ Enter the name, if not already proposed, and press to confirm.

▶ Modify the number if necessary and press to save record.

▶ SAVED

### 5.4 DELETING A RECORD FROM THE LIST OF CALLS

When a call record is displayed:



- 1 Press the button.

▶ STORE?



- 2 Press the or buttons and select erase?

▶ ERASE?



- 3 Press the button to confirm.

▶ ERASED

### 5.5 CALLING A CORRESPONDENT FROM THE LIST OF CALLS

When a call record is displayed:



- 1 Press the or button, or pick up the handset.

▶

Set up the call by either by picking up the handset or changing to hands-free mode.

## 6. CONNECTING AND USING A HEADSET\*

### 6.1 CONNECTING A HEADSET

Plug the headset cable into the socket on the base of the telephone.

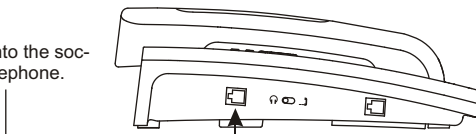

### 6.2 USING A HEADSET

▶ To use the headset, once you have plugged it in:

- 1 Pick up the handset.
- 2 Slide the switch on the base towards the headset icon.
- 3 Dial the number.

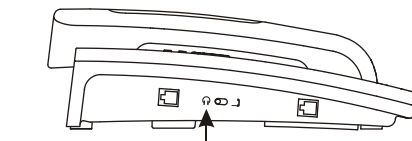

▶ You can now use the telephone in the normal way.

If you want to continue with your conversation using the handset instead, slide the switch back towards the handset icon.

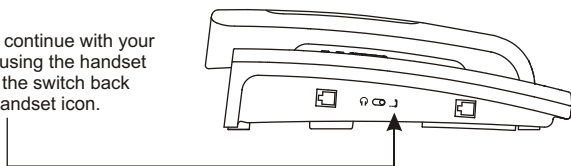

\* Not included with the **TEMPORIS 500**.

Your headset must have an RJ9 connector.

Please use headsets that are compliant with EN60950-1 and designed to be used with telephones.

## 7. ADDITIONAL INFORMATION

### 7.1 TROUBLESHOOTING

PROBLEM	CAUSE	SOLUTION
The screen have no display. There is no dial tone.	The telephone is not properly connected.	Try re-connecting the telephone.
The screen have no display. There is dialing tone.	The telephone was not initialised or the batteries are not in place.	Pick up the handset and wait for the information to be displayed on the screen. Or insert the batteries. (See installation section)
The telephone does not ring.	The ringer has been disabled.	Refer to the " Selecting and adjusting the melody & the Volume" chapter.
Unable to unlock PIN.	Wrong PIN code.	<ol style="list-style-type: none"> <li>1. Unplug the line code.</li> <li>2. Remove the batteries (if batteries are used).</li> <li>3. Wait for a minute.</li> <li>4. Replace with battery.</li> </ol> In case of use without batteries, connect the line cord. 5. Within 2 seconds, press "  " key, then " R " key. (All memory & setting will be deleted)
No dialing tone when the set is connected to a "Telephony on Internet" box.	The phone is configured in pulse dialing mode.	Press "Menu" key, then "OK". Go to "CALL SETTING" press "OK". Go to "DIAL MODE" Press "OK". Choose "TONE" Press "OK".



## 7.2 DEFAULTS SETTINGS

Contrast	Level 3
Language	French
Ring tone	1
Area code	Empty
Voice mail	Empty
Dial mode	Tone
Flash time	100ms
Pause time	2 S





### 7.3 GUARANTEE

Your **TEMPORIS 500** telephone is approved in conformity with European regulations, as attested by the CE mark.

You are covered by a legal guarantee on this product. For all information concerning this guarantee, please contact your reseller.

Regardless of the legal warranty covering the product, the reseller guarantees conformity of the products with their technical specifications for a period of twelve (12) months, parts and labour, starting from the date appearing on the proof of purchase of the product. You should therefore retain your invoice or till receipt specifying the date of purchase of the product and the name of the reseller. However, if the legal warranty applicable in your country exceeds twelve (12) months, then the legal warranty alone applies. The non-conforming part or product will be repaired or replaced free of charge, by an identical part or product, or one at least equivalent in terms of functionality and performance. If it proves impossible to repair or replace the item, the product will be reimbursed.

The spare product or part, which may be either new or reconditioned, is guaranteed either for three months from the date of repair or until the end of the initial warranty period, whichever is the longer. All parts or products returned and replaced become the property of the manufacturer.

However, this warranty does not apply in the following cases:

- installation or use in a way that fails to comply with the instructions contained in this guide;
- incorrect connection or non-standard use of the product, notably with accessories not designed for the purpose;
- normal wear and tear;
- failure to comply with the technical and safety standards prevailing in the state or country of use;
- devices subjected to shocks or falls;
- devices damaged by lightning, voltage surge, heat sources or radiation therefrom, water, exposure to excessive humidity, or any other cause external to the product itself;
- negligence or poor maintenance;
- maintenance, modification or repair of the product by persons not authorised by the manufacturer or reseller.

SUBJECT TO LEGAL PROVISIONS, ALL WARRANTIES OTHER THAN THOSE DESCRIBED HEREIN ARE EXPRESSLY EXCLUDED.





This symbol means that your inoperative electronic appliance must be collected separately and not mixed with the household waste. The European Union has implemented a specific collection and recycling system for which producer's are responsible.

This appliance has been designed and manufactured with high quality materials and components that can be recycled and reused. Electrical and electronic appliances are liable to contain parts that are necessary in order for the system to work properly but which can become a health and environmental hazard if they are not handled or disposed of in the proper way.

Consequently, please do not throw out your inoperative appliance with the household waste.

If you are the owner of the appliance, you must deposit it at the appropriate local collection point or leave it with the vendor when buying a new appliance.

- If you are a professional user, please follow your supplier's instructions.
- If the appliance is rented to you or left in your care, please contact your service provider

***Please help us protect the environment in which we live!***

## 7.5 SAFETY

- Your telephone must be kept away from sources of excessive heat (radiators, direct sunlight, etc..) and protected against vibrations and dust. Never allow your telephone to come into contact with water or other liquids or aerosols.
- Working temperature range: + 5 °C to + 40 °C.
- Your telephone must be installed at least 1 metre away from electrical equipment such as a TV, mobile phone, computers, minitels, halogen hot-plates, halogen lamps. If you use your telephone on a broadband line (ADSL modem), remember to use an ADSL filter.

To clean your telephone, use a lightly moistened antistatic cloth.

Warning: the same standard classifies the mains voltage as dangerous.



## 7.6 PRECAUTIONS

Warning, your telephone must never come into contact with water.

You may, however, use a damp cloth to clean it.

Never use solvents (trichlorethylene, acetone, etc.), which may damage the plastic surfaces. Never spray cleaning products on your phone.

We advise you not to use the telephone during storms.

Only use batteries with specifications identical to those mentioned in this guide (see the section "Inserting or replacing the batteries"). The use of batteries that do not conform represents a health risk and may damage your telephone.

Do not attempt to open the batteries, as they contain chemical substances. In the event of leakage, avoid contact with the skin, eyes, mouth and nose. In the event of contact, rinse the affected part for twenty minutes in running water and seek medical assistance immediately.

In the event of danger, the mains adapter acts as 230V power isolating device. It should therefore, as a precaution, be installed close to the appliance and be easily accessible.

Clean the telephone with absorbent paper or a dry cloth and contact your reseller to change your batteries.

***!Do not use your telephone to notify a gas leak when you are in the vicinity of the leak.***

We recommend that you avoid using this device during electrical storms.





**THOMSON**

Thomson Telecom

Head office: 46, quai Alphonse Le Gallo 92648 Boulogne Cedex - France

SAS Capital 130 037 460 € - 390 546 059 RCS Nanterre

© Thomson Telecom 2005 - All rights reserved.  
The manufacturer reserves the right to modify the specifications of its products in order to make technical improvements or comply with regulatory requirements.  
Alcatel logo and Alcatel name are trademarks of Alcatel and used under license by Thomson Telecom.

Ref: 905-T500004-00 06/12/05

